

SERIE 03
03316

3-way ball valves with threaded ends, stainless steel

Nominal diameter options (DN) 15-50
Maximum working temperature 180 °C



TYPE 03316

Three-way, with ball "L" shape or "T" shape, with ISO 5211 flange

FEATURES

Applications: Suitable for chemical and industrial plants, for heating and conditioning (HVAC), district heating, agricultural applications, oils and hydrocarbons.

Directive: In conformity with directive 97/23/CE PED

Construction and testing norms (correspondences):
Threading: ISO 228-1, BS (BSP).
Design: EN13445, ISO 5211
Testing: EN 12266 cat. A (ISO 5208 cat. A)

Maintenance free

* Ball valve can be equipped with hydraulic, pneumatic or electric actuator. Ask more from Econosto Oy sales.

3-way ball valves with threaded ends Stainless steel

SERIE 03

TYPE 03316 - 3-way ball valve

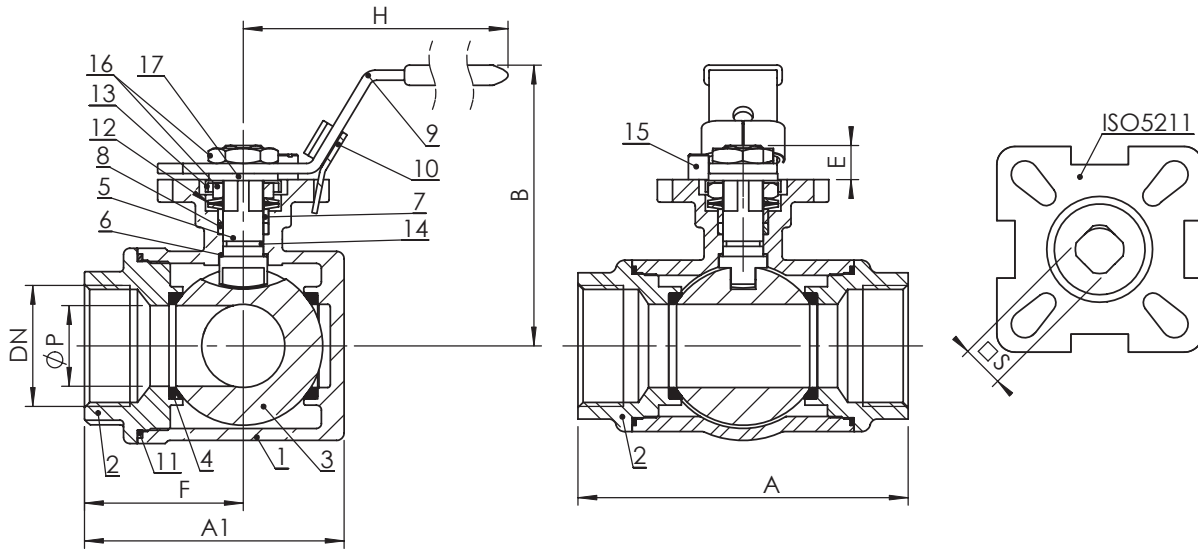

Materials

	Component	Material
1	Body	AISI 316
2	Liner	AISI 316
3	Ball	AISI 316
4	Ball seat	Reinforced PTFE
5	Stem	AISI 316
6	Sliding washer	PTFE
7	Ring	AISI 304
8	Stem seal	PTFE
9	Lever	AISI 304 with plastic sleeve
10	Lock device	AISI 304
12	Belleville Spring	AISI 301
13	Spacer	AISI 304
14	O-ring	FKM (Viton®)
15	Lever stop pin	AISI 304
16	Nut	AISI 304
17	Spring washer	AISI 301
18	Tie rod	AISI 304

Dimensions (mm)

DN	1/4"	3/8"	1/2"	3/4"	1"	1" 1/4	1" 1/2	2"
P	9,5	11	12	15	20	25	32	40
A	75	75	75	85	100	122	131	158
A1	57,5	57,5	57,5	65,5	79	97	106,5	129
F	37,5	37,5	37,5	42,5	50	61	65,5	79
B	130	130	130	161	161	203	203	203
H	66	66	66	2	77	92	96	107
S	9	9	9	11	11	14	14	14
ISO 5211	F03/F04	F03/F04	F03/F04	F04/F05	F04/F05	F05/F07	F05/F07	F05/F07

Weight (kg)

04.622	0,70	0,67	0,63	0,94	1,39	2,91	3,66	6,31
--------	------	------	------	------	------	------	------	------

Operating torque (Nm)

Nm	8	8	8	9	15	20	30	45
----	---	---	---	---	----	----	----	----

N.B.: In order to choose the right actuator, we recommend multiplying the operating torque figure by a safety coefficient, K=1.5