

SERIE 03
 0336BW

Ball valves with butt-weld/screwed ends

Nominal diameter options (DN) 6-100
 Nominal pressure options (PN) 64
 Maximum working temperature (°C) 180

FEATURES

3 piece design (screwed), maintenance free, full bore.
 Mounting pad for actuator acc. to ISO5211.

Fire safe approval, Anti-static device.

Lockable handle, stem seals with spring washer set and lock plate, maintenance free. Body parts with centring grooved and tongued, for ease assembly.

- Rotation of the handle through 90°
- Temperature range -30 °C up to 180 °C
- Connection: Female B.S.P. thread 1/2" - 4", DIN 2999
- Face to face: Threaded connection DIN 3202 M3,
 Welded connection DIN 3202 S13



PRESSURE TEMPERATURE DIAGRAM
 (PTFE)

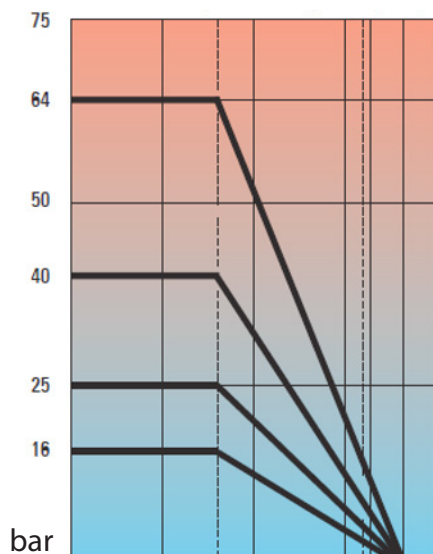

KV-VALUE

SIZE ["]	KV-VALUE [m3/h]
1/2	36
3/4	59
1	90
1 1/4	159
1 1/2	230
2	418
2 1/2	725
3	1098
4	1768

* Ball valve can be equipped with hydraulic, pneumatic or electric actuator. Ask more from Econosto Oy sales.

Ball valves with butt-weld ends,
stainless steel, fire safe

SERIE 03

PART AND MATERIAL LIST

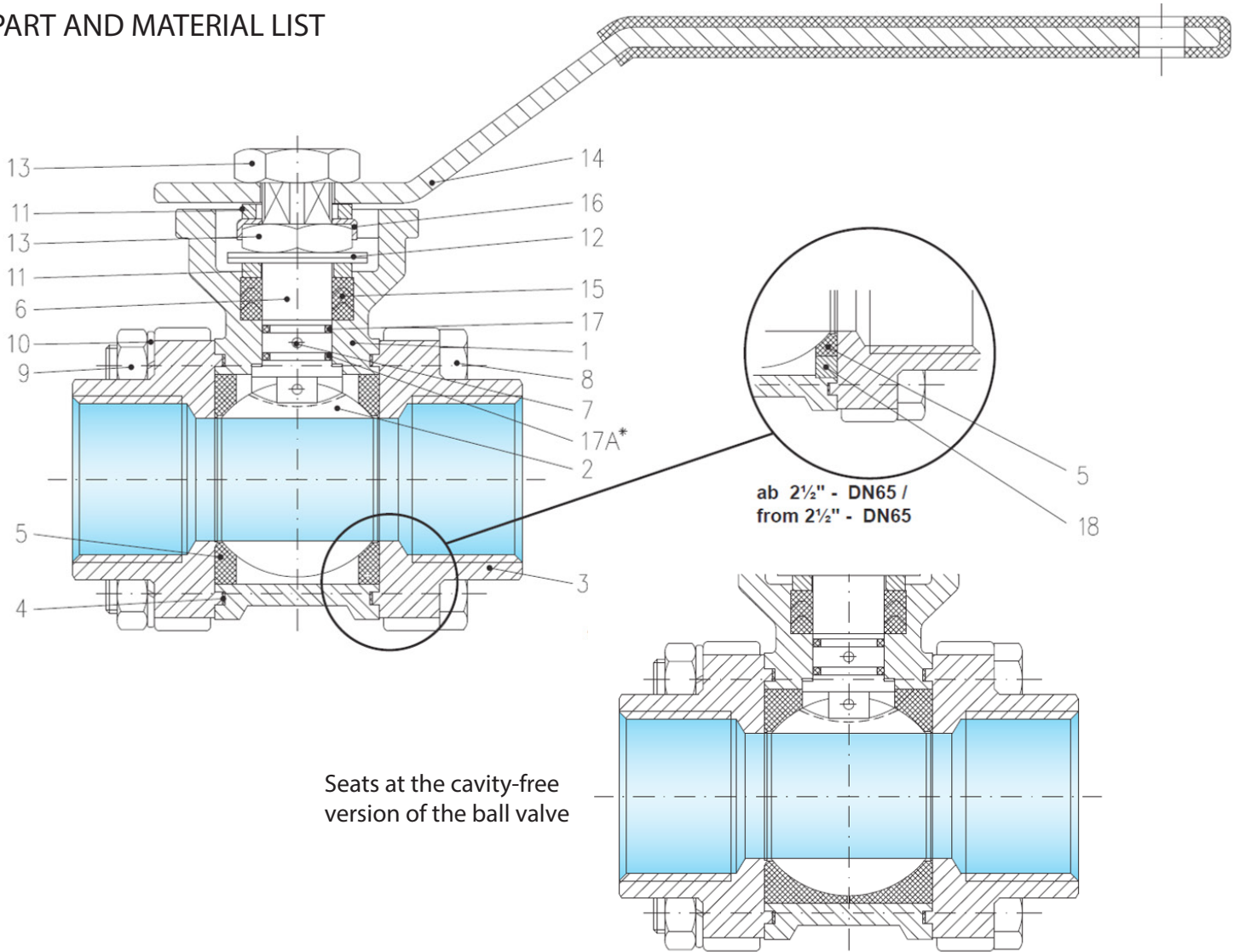

Seats at the cavity-free
version of the ball valve

PART	MATERIAL
1. Body	Stainless steel 1.4408 (AISI316)
2. Ball	
3. Connection end	
4. Body seals	Graphite
5. Ball seals	PTFE+15% glassfiber reinforced
6. Stem	Stainless steel 1.4401 (AISI316)
7. Anti-static device	
8. Hexagon screw	Stainless steel 1.4403 (AISI304)
9. Hexagon nut	
10. Lock washer	
11. Gland ring	

PART	MATERIAL
12. Spring washer	Stainless steel 1.4310 (AISI301)
13. Hexagon nut	Stainless steel 1.4301 (AISI304)
14. Handle	
15. Stem seals	Graphite
16. Lock plate	Stainless steel 1.4301 (AISI304)
17. O-ring	FKM
17A. O-ring (from 1 1/2" / DN40)	FKM
18. Center ring	Stainless steel 1.4301 (AISI304)

DIMENSIONS

Dimension table on page 4.

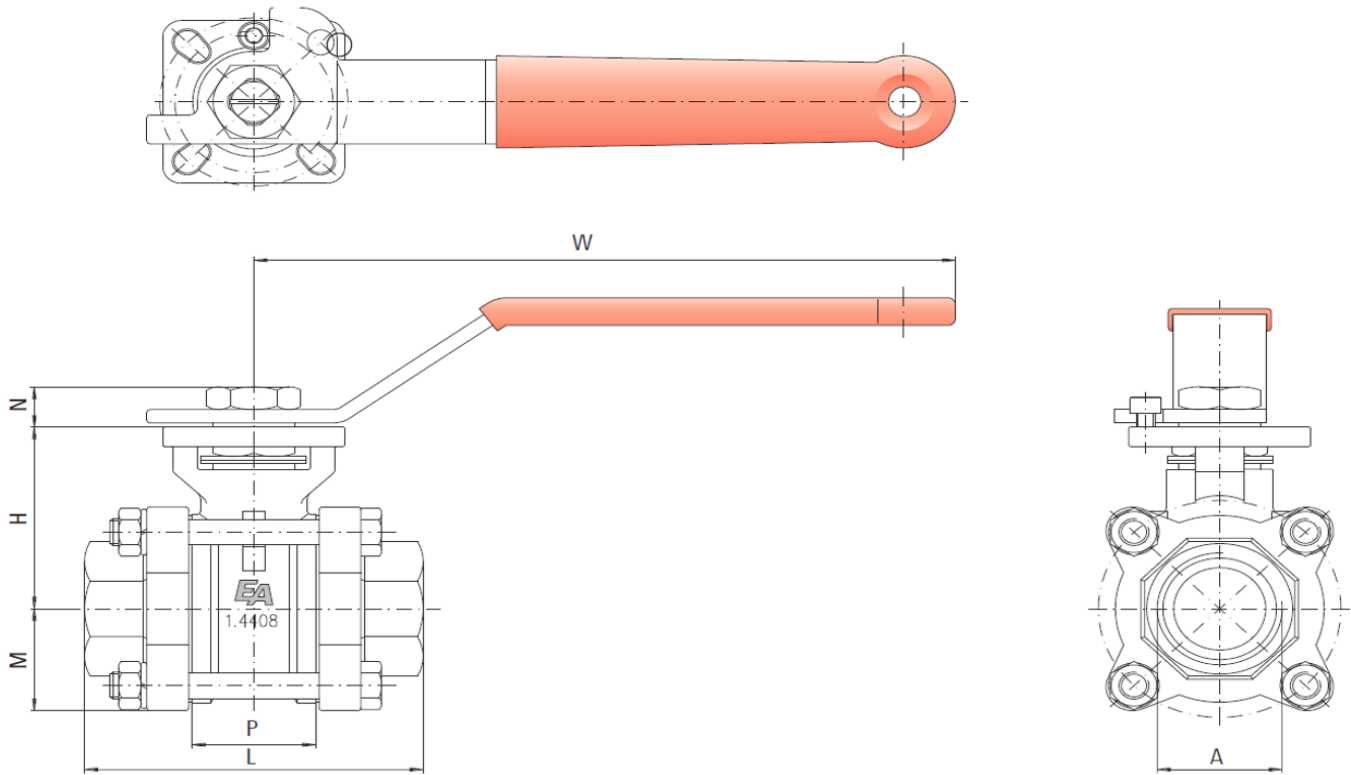

Threaded connection

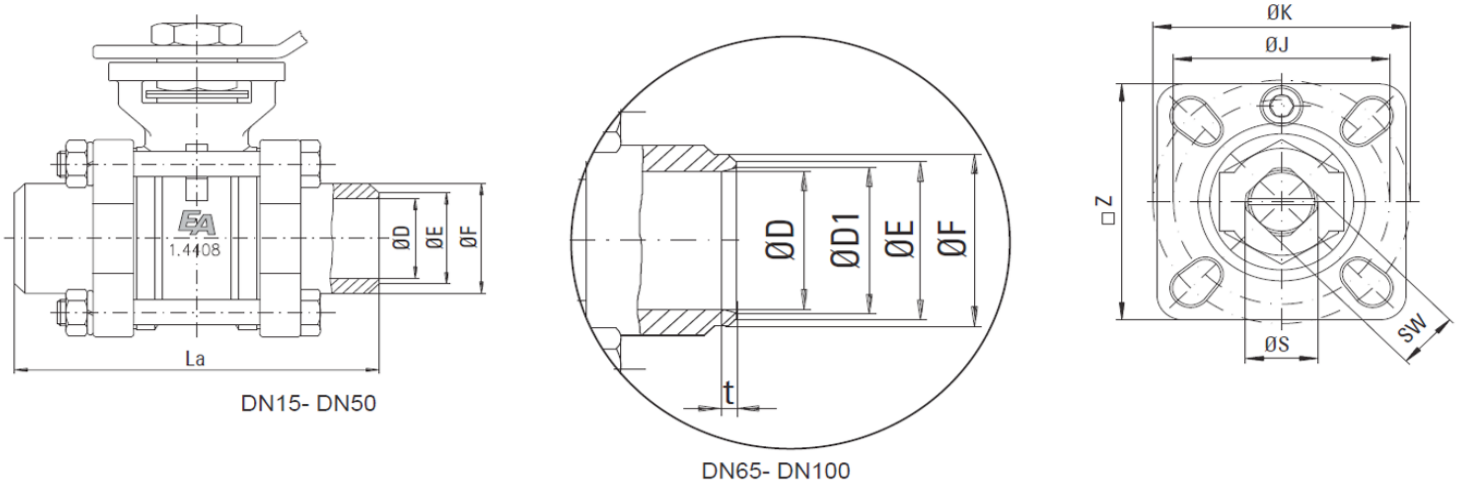

Welded connection

DIMENSIONS

A	DN	øD	L	La	øE	øF	P	M	H	N	øK	øJ	øS	SW	Z	W	kg
1/2	15	16	75	75	17	22,4	25,2	22,5	42,3	8	42	36	11,1	9	42	113,5	0,52
3/4	20	20	80	90	22	28,2	27,9	27,2	44,8	8	42	36	11,1	9	42	113,5	0,81
1	25	24,5	90	100	28	33,7	33	30,3	54	10	50	42	14,3	11	48	186,5	1,26
1 1/4	32	34	110	110	37	44,0	41,2	36,9	59,2	10	50	42	14,3	11	48	186,5	1,86
1 1/2	40	38	120	125	43	50,8	49,3	40,6	73,5	14,8	70	50	18	14	68	221,5	2,95
2	50	51	140	150	54	62,6	63,6	50,1	82,9	14,8	70	50	18	14	68	221,5	4,47
2 1/2	65	65	185	190	70	76,1	82,1	82	107	17,1	102	70	22	17	94	350	9,72
3	80	80	205	220	82	88,9	95,8	88	117,3	17,1	102	70	22	17	94	350	14,91
4	100	100	240	270	106	114,3	117,8	115	132,3	17,1	102	70	22	17	94	350	24,2

WELDING INSTRUCTIONS

For parts with welded connections:

Remove connection parts from the middle-part of the valve, to prevent damage of the seals die to high welding-temperatures. In case of already installed pipework, insert a distance-part between the connection parts and fix it with the help of the tie-rods. Before welding ensure that the pipe-connections are aligned. After succesful welding and cooling reassemble the valve.