

SÄHKÖISET TOIMILAITTEET ELECTRIC ACTUATOR HQ-004

Small & Compact
Unique control
Weather proof



LAAJA VALIKOIMA:
WIDE RANGE:
8 - 300 Nm / torque



 **Econosto Oy**

ECONOSTO OY
PL 1330, Yrittäjäntie 20
70151 KUOPIO
FINLAND

Tel +358 (0)17 262 3555
Fax +358 (0)17 262 3511
www.econosto.fi
info@econosto.fi

DESCRIPTION

- HQ 004 electric actuator is specially designed for small size quarter turn valve operation such as Ball, Butterfly, Plug valves/Dampers and similar usages.

FEATURES

- Compact and light weight
- High corrosion resistance
- Multi-voltage : (AC85~265V/1PH, 24V DC)
- Standard space heater (0.5W)
- Weather proof (IP67)
- Push button and Manual lever
- Mounting base : standard ISO5211(F03/F04/F05)
- Standard 4 limit switches
- Captive cover bolt
- Mechanical position indicator & LED lamp indicators(Open/Close)
- Lead type cable wires



OPTION

- PIU : Potentiometer unit(1K~10K)
- PCU : Proportional control unit(in/out:0-10V, 4-20mA)
- CPT : Current position transmitter(output 4-20mA DC)

CONSTRUCTION

Auto,manual push button

Cable entry and wire

Long Wire type(10p)
Standard Wire length: 1.2m
PG11 CABLE PLUG

Full close lamp (blue)

Full open lamp (red)

Indicator

Main board

4Limit switches

Add CLOSE L/M S/W(White)
Add OPEN L/M S/W(Black)
Close L/M S/W(Green)
OPEN L/M S/W(Red)

4Captive bolt

Manual lever connecting hole

Mounting base(ISO5211)
F03,F04,F05

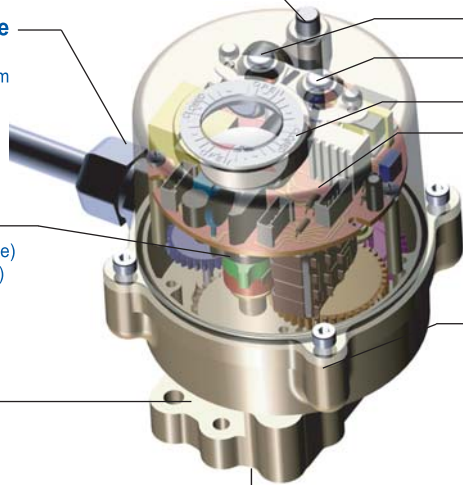

PERFORMANCE

TYPE (MODEL)	MAXIMUM OUTPUT TORQUE		OPERATING TIME 60/50Hz	MOUNTING SIZE	ELECTRIC MOTOR STOP	SUPPLYING POWER & RATED CURRENT(A) 60/50Hz, 1 Phase			DUTY CYCLE IEC34-1	MANUAL LEVER ANGLE	WEIGHT
	Kg.m	N.m	90°	ISO5211	A	AC110V	AC220V	DC24V	S2 (%)	DEGREE	kg
HQ-004	4	40	11 Sec	F03,F04,F05	2A	0.1A	0.06A	1A	50	90°± 5	1.2

DIMENSION

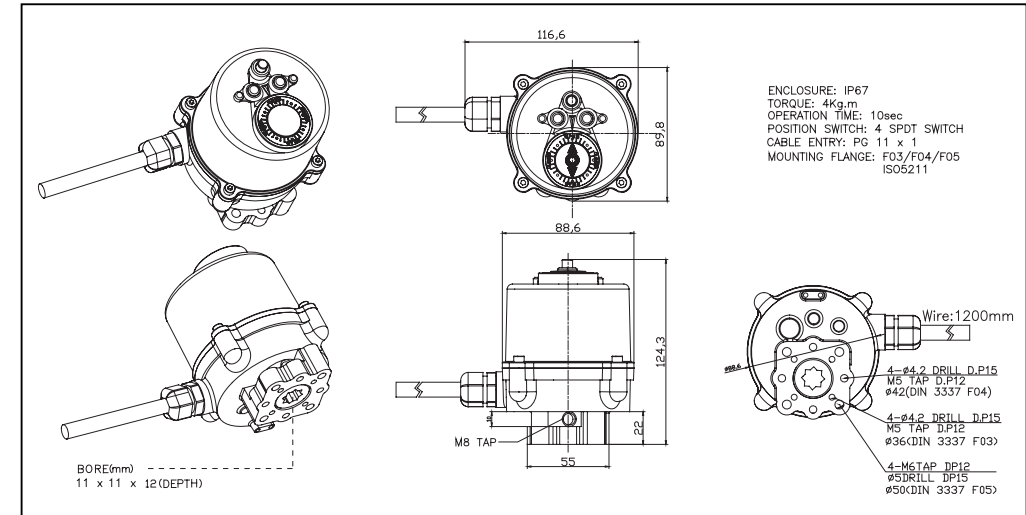

APPLICATION

